

# WHIPPLE

## WHIPPLE 2.7-3.5L ECOBOOST INSTRUCTION MANUAL 2015 AND UP FORD F150 MEGA COOLER INSTALL



WHIPPLE SUPERCHARGERS  
3292 NORTH WEBER AVE  
FRESNO, CA 93722  
TEL 559.442.1261  
FAX 559.442.4153

[www.whipplesuperchargers.com](http://www.whipplesuperchargers.com)

*A color PDF of this manual is available, email  
[tech@whipplesuperchargers.com](mailto:tech@whipplesuperchargers.com) for a copy*

**PREMIUM FUEL ONLY (91 OCTANE OR BETTER ALWAYS) RON+MON/2**

*COMPETITION BASED PRODUCT MAY BE USED SOLELY ON VEHICLES USED IN SANCTIONED COMPETITION WHICH  
MAY NEVER BE USED UPON A PUBLIC ROAD OR HIGHWAY*

## INTRODUCTION

Before beginning installation, please read this manual and important notes:

- Please read the installation manual and verify that all items are present. If you are missing hardware or have any questions, please contact your dealer or Whipple.
- COMPETITION BASED PRODUCT MAY BE USED SOLELY ON VEHICLES USED IN SANCTIONED COMPETITION WHICH MAY NEVER BE USED UPON A PUBLIC ROAD OR HIGHWAY, UNLESS PERMITTED BY SPECIFIC REGULATORY EXEMPTION (VISIT THE "EMISSIONS" PAGE AT [HTTP://WWW.SEMASAN.COM/EMISSIONS](http://www.semasan.com/emissions) FOR STATE BY STATE DETAILS.
- COMPETITION BASED PRODUCT IS LEGAL IN CALIFORNIA ONLY FOR RACING VEHICLES WHICH MAY NEVER BE USED, OR REGISTERED OR LICENSED FOR USE, UPON A HIGHWAY.
- IT IS THE RESPONSIBILITY OF THE INSTALLER AND/OR USER OF THIS PRODUCT TO ENSURE THAT IT IS USED IN COMPLIANCE WITH ALL APPLICABLE LAWS AND REGULATIONS.

## RECOMMENDED TOOLS AND SUPPLIES

The following items are not included in this supercharger kit and it is strongly recommended that they're used for ease of installation or maximum performance.

Safety glasses, 3/8" torque wrench, 3/8" assorted metric socket set, trim pad tool (for pushpin removal), floor jack.

## PRE-INSTALLATION CHECKLIST

Before installing your Whipple Kit, complete the following checklist.

1. Verify Condition of Vehicle: Before the upgrade kit is installed, ensure the engine runs smoothly and that the factory malfunction indicator light (MIL) is off. Only install the supercharger kit if the engine runs smoothly *and* the MIL is off.
2. **!! CAUTION !!** This product is intended for use only on STOCK, UNMODIFIED, WELL-MAINTAINED engines. Installation on a worn-out or modified engine is not recommended without factory computer and fuel system modifications. Custom engine configurations could require custom tuning and other supporting modifications.
3. Verify Fuel System: Upgrade systems should only be installed on vehicles that have new or clean fuel filters.
4. Assess Cleanliness of Installation Area: Make sure your work area and the under-hood area are free from debris. This supercharger is a high-quality, close-tolerance compressor and must not be subjected to contamination by dirt or any type of foreign material. If necessary, vacuum around engine to remove any foreign material.
5. **!! CAUTION !!** Identify Kit Components: Before beginning installation, identify all the components of your Whipple Kit and ensure all items are present and undamaged.

## **SAFETY PRECAUTIONS**



### **CAREFULLY READ THE IMPORTANT SAFETY PRECAUTIONS AND WARNINGS BEFORE PROCEEDING WITH THE INSTALLATION!**

Appropriate disassembly, assembly methods and procedures are essential to ensure the personal safety of the individual performing the kit installation. Improper installation due to the failure to correctly follow these instructions could cause personally injury or death. Read each step of the installation manual carefully before starting the installation.

- Always wear safety glasses for eye protection.
- Place the ignition switch in the off position.
- Always apply the parking brake when working on vehicle.
- Block the front and rear tire surfaces to prevent unexpected vehicle movement.
- Operate the engine only in well-ventilated areas to avoid exposure to carbon monoxide.
- Do not smoke or use flammable items near or around fuel system.
- Use chemicals and cleaners only in well-ventilated areas.
- Batteries can produce explosive hydrogen gas which can cause personal injury. Do not allow flames, sparks or flammable sources to come near the battery.
- Keep hands and any other objects away from the radiator fan blades.
- Keep yourself and your clothing away from moving parts when the engine is running.
- Do not wear loose clothing or jewelry that can be caught in rotating or moving parts.



### **WARNING**

**\*\*NOTICE:** Installation of Whipple products signifies that you have read this document and have agreed to the terms stated within.

*It's the purchaser's responsibility to follow all installation instruction guidelines and safety procedures supplied with the product as it's received by the purchaser to determine the compatibility of the product with the vehicle or the device the purchaser intends to install the product on.*

*Whipple assumes no responsibility for damages occurring from accident, misuse, abuse, improper installation, improper operation, lack of reasonable care or all previously stated reasons resulting from incompatibility with other manufacturer's products.*

*There are no warranties expressed or implied for engine failure or damage to the vehicle in any way, loss of use or inconvenience or labor reimbursement. This includes merchantability and fitness.*

*The information contained in this publication was accurate and in effect at the time the publication was approved for printing and is subject to change without notice or liability. Whipple reserves the right to revise the information presented herein or to discontinue the production of parts described at any time.*

## INSTALLATION INSTRUCTIONS

It is strongly recommended that you read through this guide **before** you begin installing the Whipple Kit.

1. Using an air hose, blow off any loose dirt or debris from engine compartment. If really dirty, then steam clean the engine compartment before proceeding to the next step.
2. Lift the vehicle using a floor hoist, if you do not have access to one, use a hydraulic floor jack and jack stands to raise the vehicle. NOTE: Jack stands must be used on a level surface and be securely seated. Failure to do so may result in personal injury or vehicle damage.
3. Remove the bolts and the spacer from the front underbody skid plate.



4. Remove the bolts and the front underbody skid plate.



5. Disconnect the intercooler fan assembly. Detach the retainer and position the wiring harness aside.

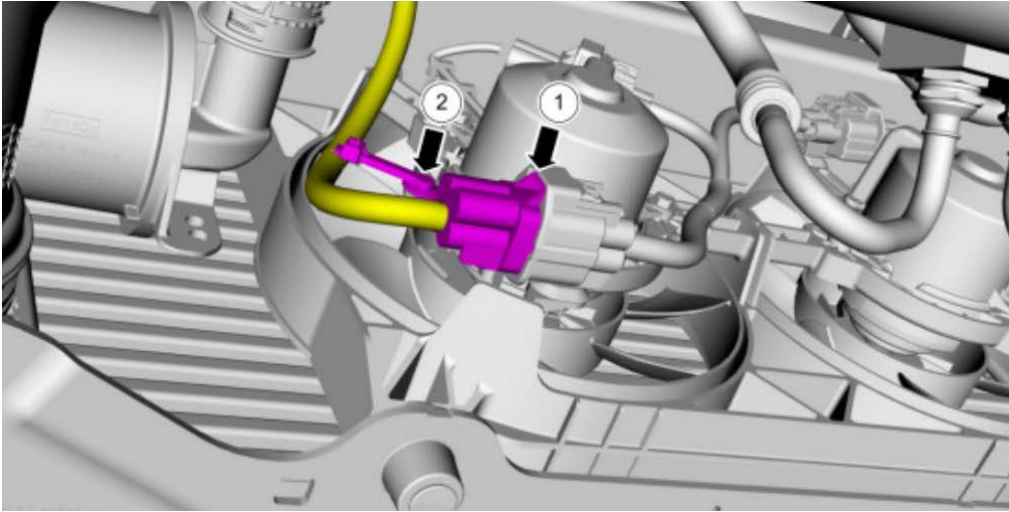

6. Remove the bolts, lower bracket and CAC cooling fan assembly.

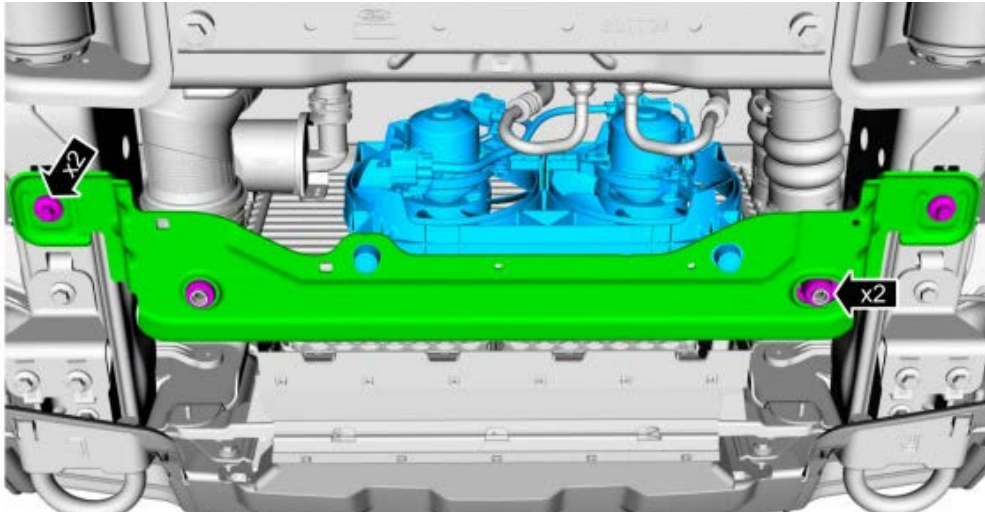

7. Using an axle stand, support the intercooler core.

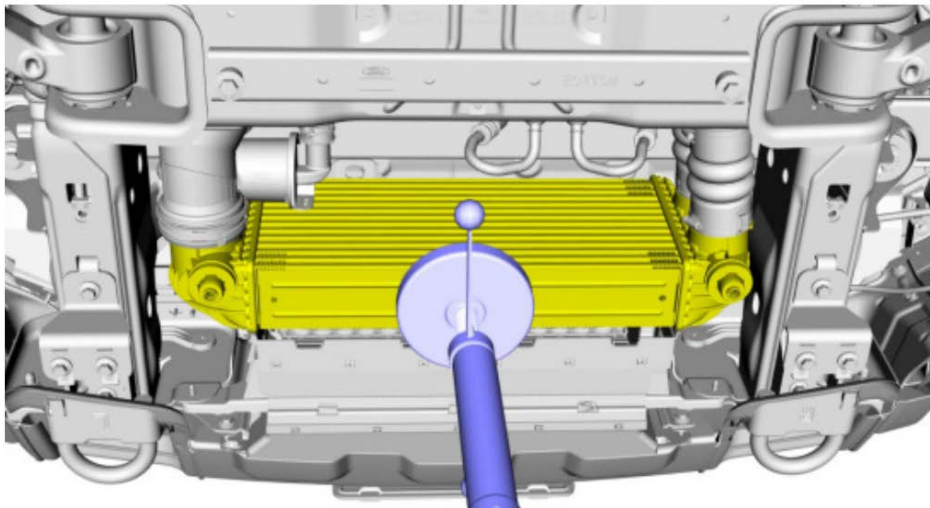

8. Loosen the clamps and position the intercooler intake pipes LH and RH aside.

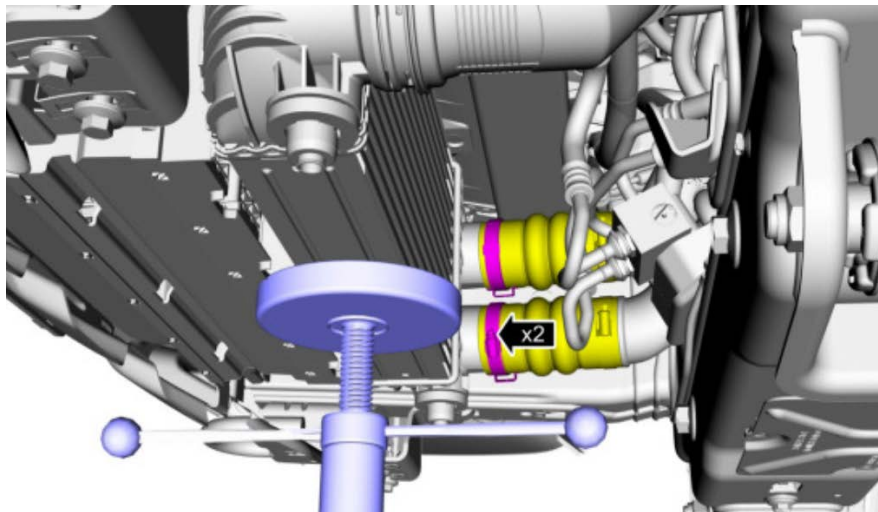

9. Disconnect the bypass valve tube. Release the clip and position the intercooler outlet pipe aside.

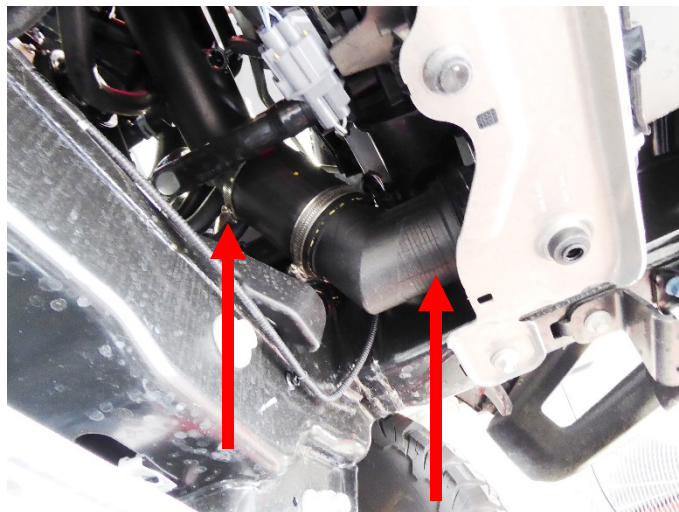
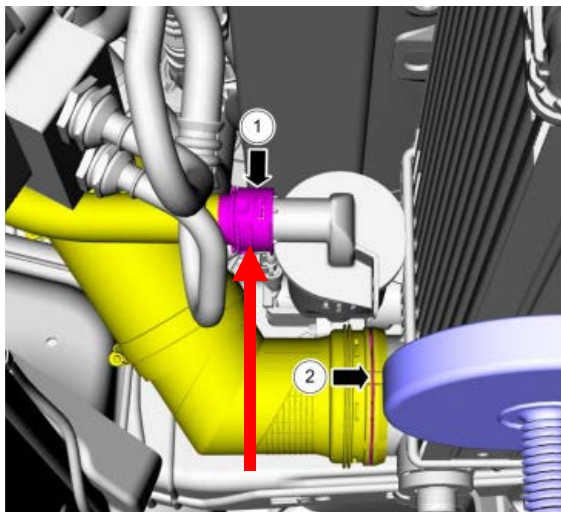

10. Remove the 45deg plastic elbow from the factory rubber hose by loosening the hose clamp (#2 in image).

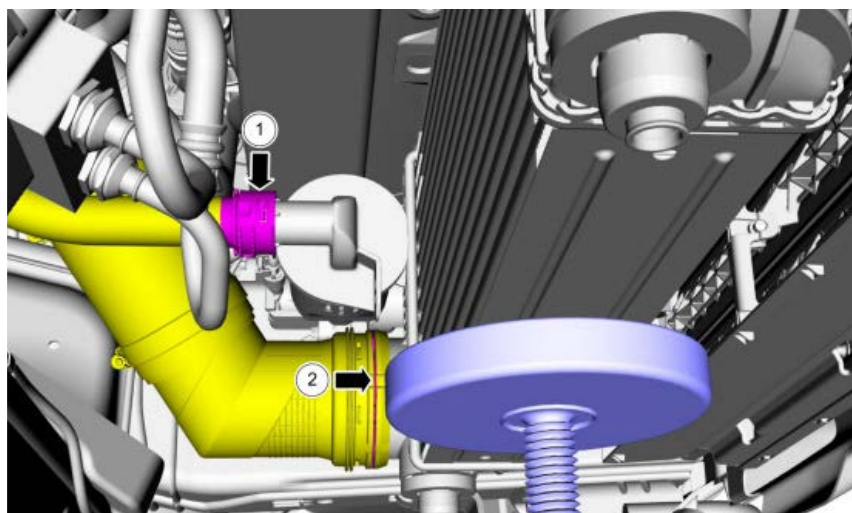

11. Disconnect the bypass valve electrical connector and place wiring harness aside.

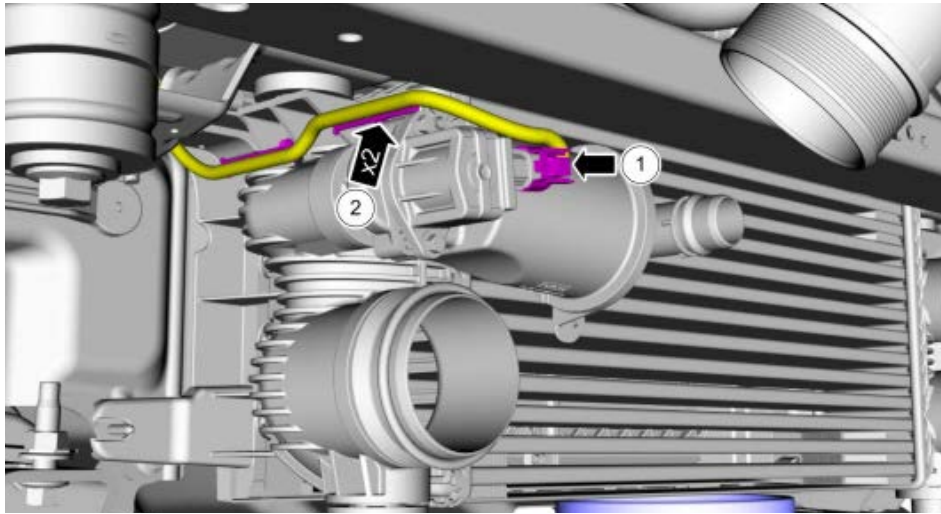

12. Lower the axle stand and remove the intercooler core from vehicle.

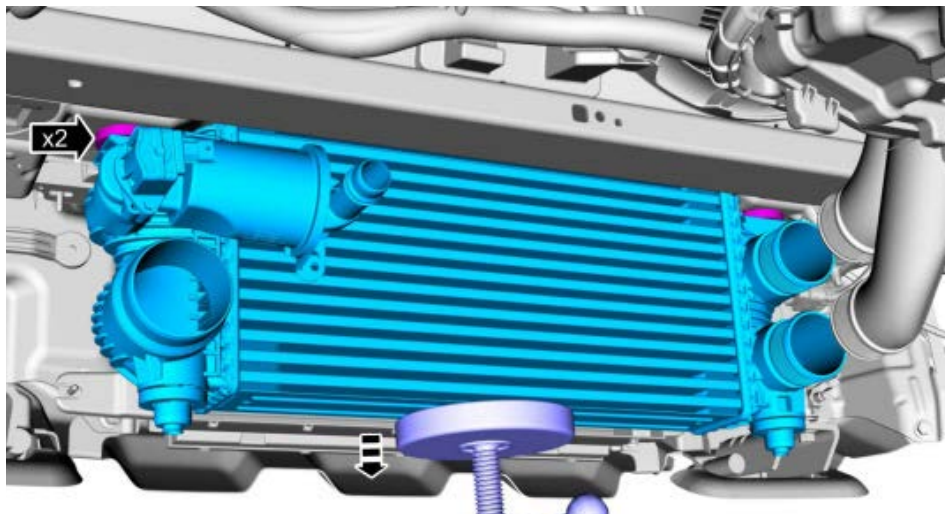

13. Remove the bolt from the turbocharger bypass valve. Rotate the bypass and remove from intercooler.

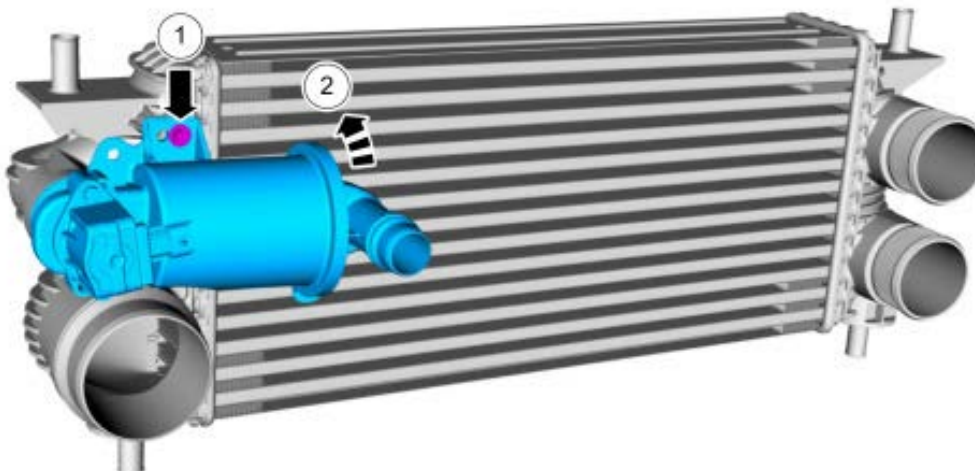

14. Mount the bypass valve to the new intercooler with the supplied 6mm x 10mm flanged hex headed bolt. Torque to 62 in-lbs.

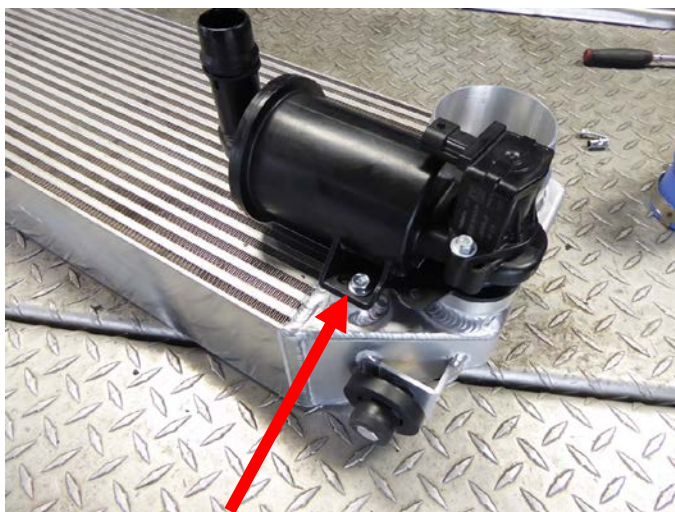

15. Transfer the rubber isolators from the OEM intercooler to the Whipple Cooler.

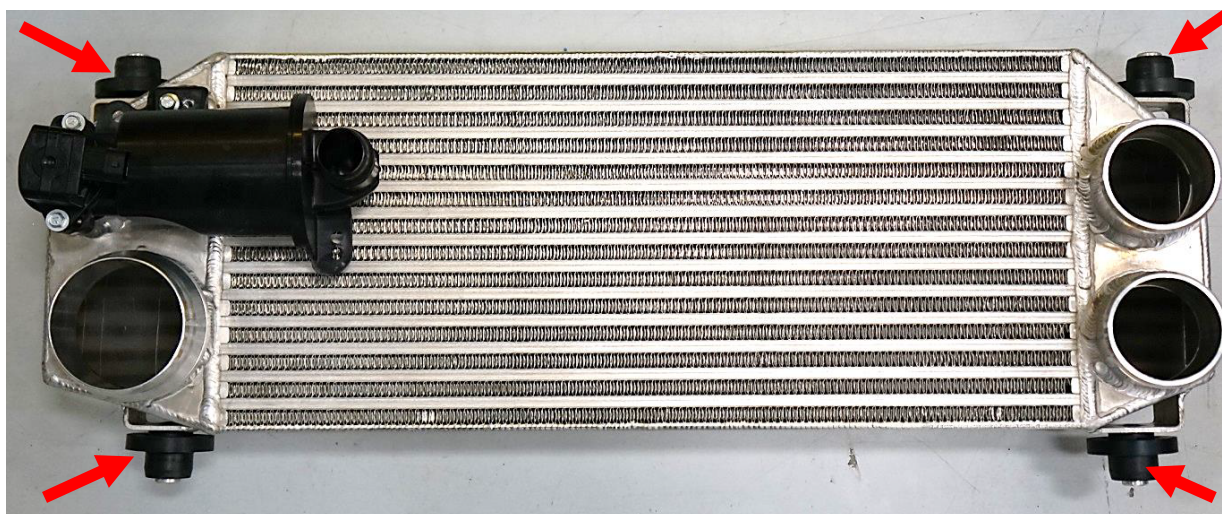

16. Install the fan assembly to the intercooler core and factory support bracket prior to reinstall.





17. Raise the axle stand and install the intercooler core from vehicle.

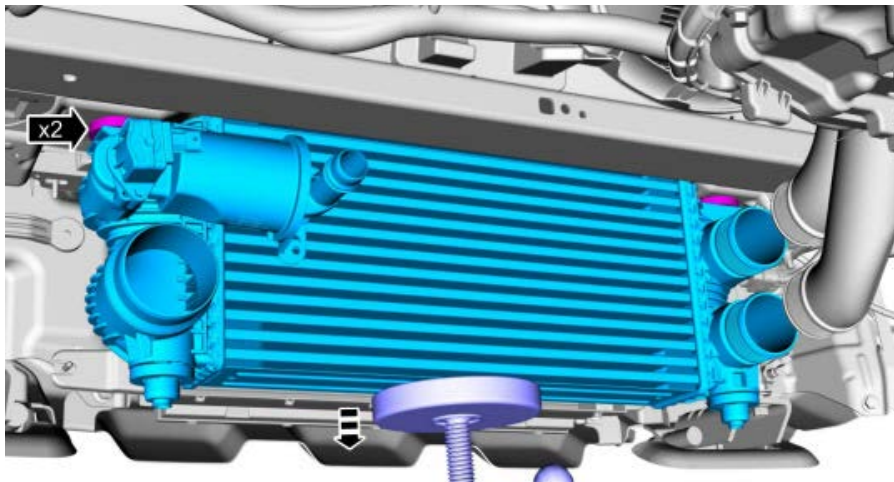

18. Connect the bypass valve electrical connector.

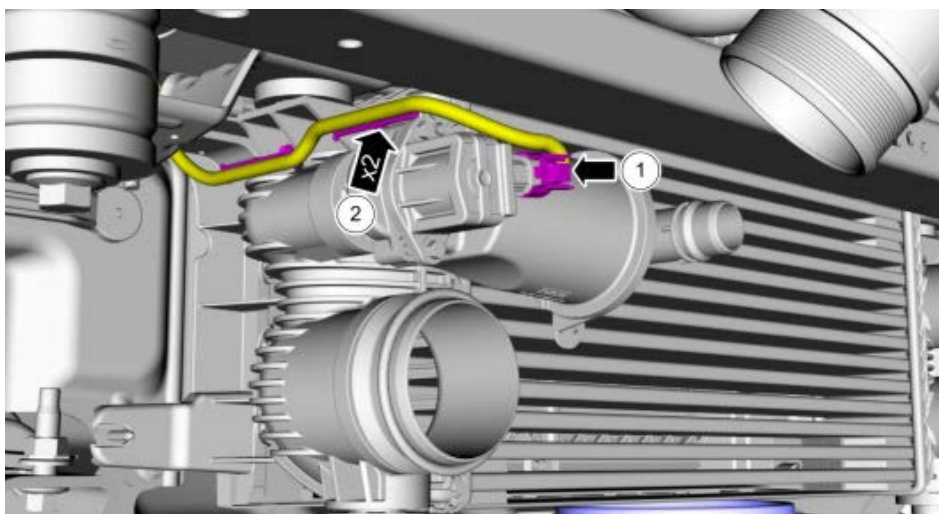

19. Connect the bypass valve tube and the supplied silicone 60deg outlet pipe. Secure outlet pipe to factory hose using supplied (1) 3.75" T-bolt clamp. Secure tube to intercooler using (1) 3.75" t-bolt clamp.

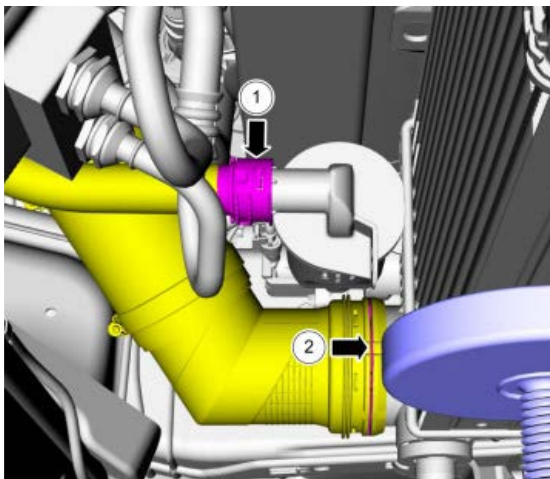

20. Install the clamps and position the intercooler intake pipes.

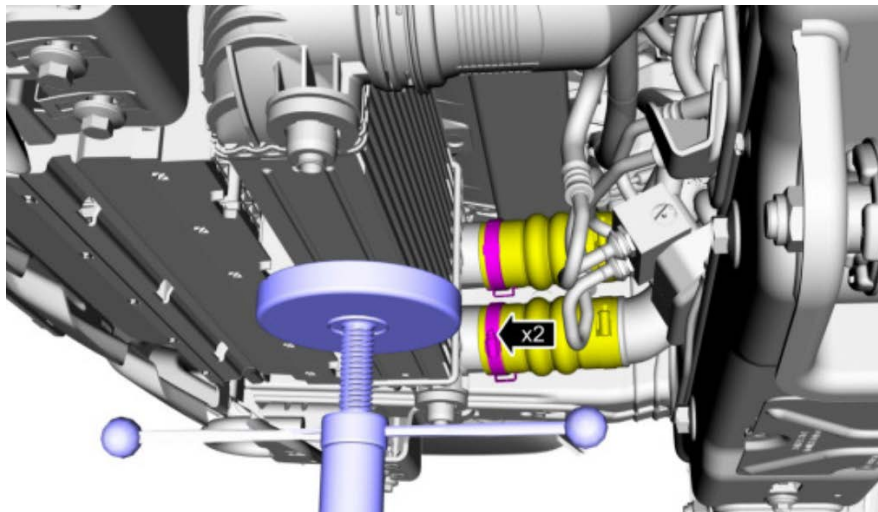

21. Install the lower bracket and fan assembly, secure with factory bolts. Torque to 30 ft-lbs.

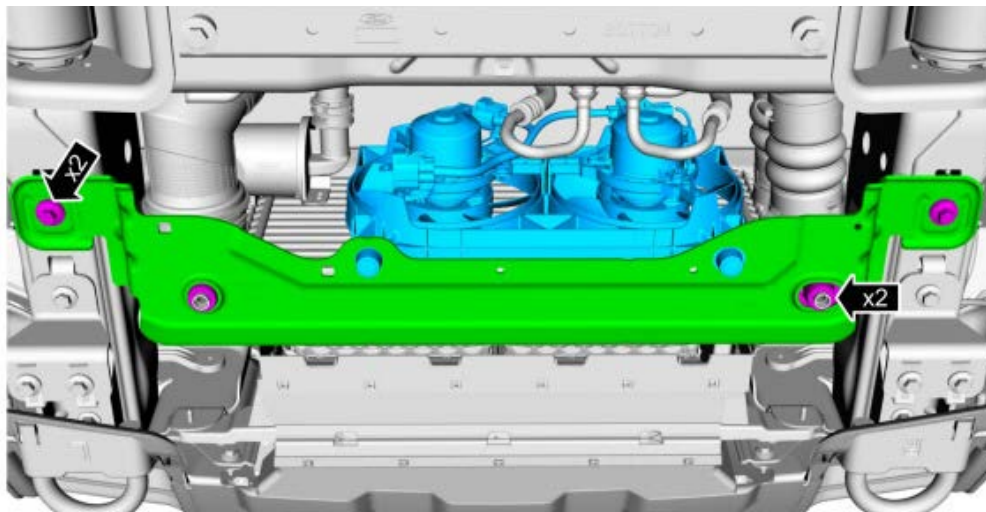

22. Connect the intercooler fan electrical connector.

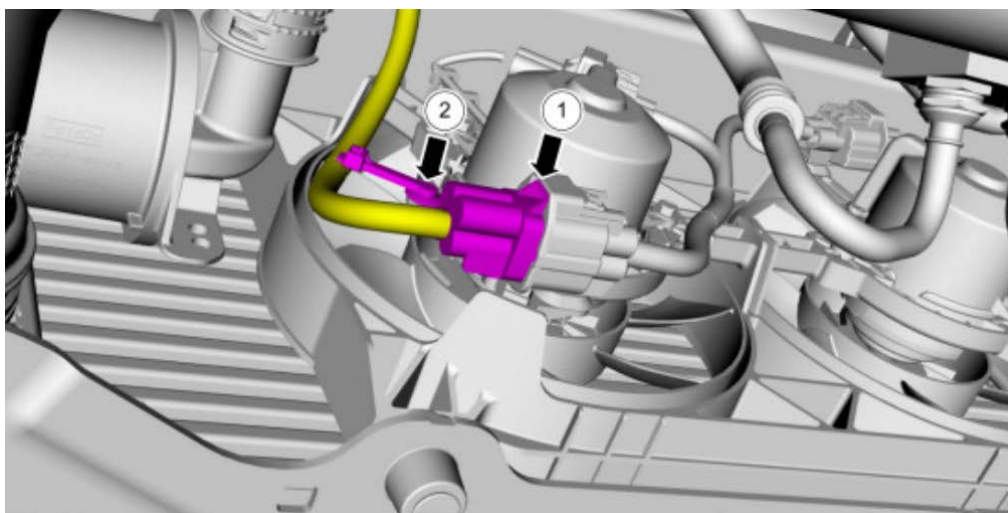

23. Reinstall the front underbody skid plate with factory hardware. Torque to 35 ft-lbs.



24. Install the underbody skid plate and spacer, secure with factory bolts. Torque to 41 ft-lbs.



25. Start the vehicle, check for any leaks or check engine lights.